

Die Grinders (3/8-24 Cone Wheels)

400GTCW Series

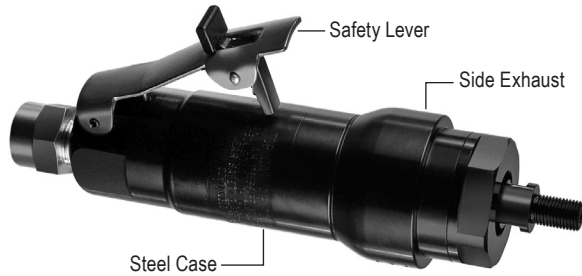

400GTSKCW;18000

407GTCW Series

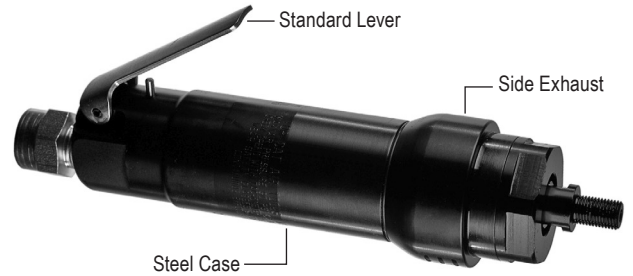

407GTSCW;15000

Max. Rated Speed	Exhaust Direction	Lever Style	MODEL NUMBER	Max. Rated Speed	Exhaust Direction	Lever Style	MODEL NUMBER		
18,000 RPM	Side	Standard Lever	400GTSCW;18000	15,000 RPM	Side	Standard Lever	407GTSCW;15000		
		Safety Lever	400GTSKCW;18000			Safety Lever	407GTSKCW;15000		
	Rear	Standard Lever	400GTSRCW;18000						
		Safety Lever	400GTSRKCW;18000						

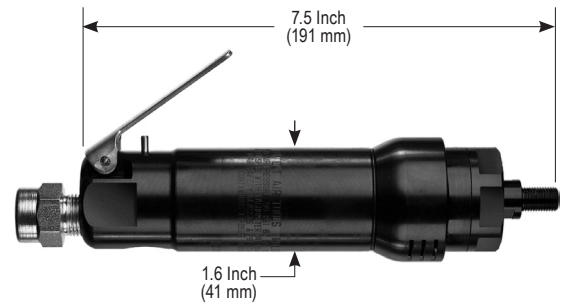
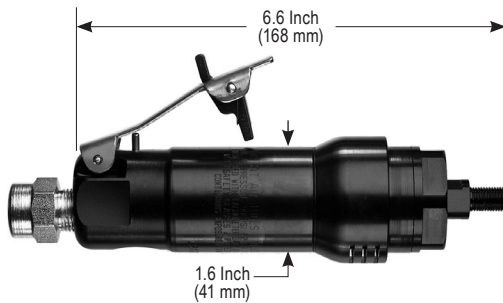

HP 1.2 H.P. (900 W)

Lbs 1.9 Lbs. (0.9 Kg) Aluminum
2.5 Lbs. (1.1 Kg) Steel

cfm 35 cfm (16.5 L/s) Max

SUPPLY 3/8" NPT Inlet
1/2" (13mm) Hose Size

HP 1.2 H.P. (900 W)

Lbs 2.0 Lbs. (0.9 Kg) Aluminum
2.6 Lbs. (1.2 Kg) Steel

cfm 35 cfm (16.5 L/s) Max

SUPPLY 3/8" NPT Inlet
1/2" (13mm) Hose Size

STANDARD EQUIPMENT

- Tool
- Operating Instructions and Service Manual
- Wrenches (sizes based on options)

400GTCW & 407GTCW Alternate Options



Cone Wheel Mounting

